



# ***Motorola Enterprise Wireless LAN Antennas***



## Using this guide

This guide has been designed to help you choose the right Motorola antenna and accessories for your wireless LAN deployment. It explains key factors to consider when choosing an antenna, and provides tables illustrating various key characteristics of each antenna. A compatibility chart is also provided to show which Motorola products are compatible with each other and what accessories may be required to complete the system. A Motorola representative or sales partner can also help you determine the best configuration for your installation.

## Table of Contents

Using this guide .....	2
Antenna Selection .....	3
Key antenna specifications.....	3
Antennas and related accessories for Motorola’s Enterprise WLANs .....	4
Choosing the right antenna and accessories.....	4
Product compatibility chart.....	5
Antenna part number and description tables .....	6
2.4 GHz (802.11b/g/n) Antennas .....	6
5 GHz (802.11a/n) Antennas .....	12
Dual-band (802.11a/b/g/n) Antennas.....	15
Cables .....	16
Adapters.....	17
Lightning Arrestors .....	18
Mounting Kits .....	19

## Antenna selection

While several antennas may work in a given environment, some will provide better coverage than others. Using the right antenna in the right location will maximize both the performance and coverage of your network. Understanding the key characteristics that describe how an antenna sends and receives radio frequency signals is critical to finding the ideal antenna.

Motorola Enterprise Wireless LAN products operate in the 2.4 GHz and 5 GHz ISM bands allocated for unlicensed use. Access point and access port products available today support either the 802.11b/g or the 802.11a standard, or both. Wireless devices conforming to the 802.11b/g standard operate in the 2.4 GHz ISM band, while 802.11a devices operate in the 5 GHz band. The antennas in this guide are grouped according to the frequency band they support. Note that some antennas are designed to operate on either band. These antennas, described as “Dual-band” may be connected to radios operating in either the 2.4 or 5 GHz bands, although a single antenna may not be connected to two radios at the same time.

## Key antenna specifications

In addition to frequency of operation, there are other key specifications to consider when choosing an antenna. These characteristics are included for each Motorola antenna in the tables on page 6, and are defined below for your reference:

### Pattern

**Omni-Directional:** Signal radiates from the antenna in all directions on the horizontal plane.

**Directional:** Signal radiates in a specific direction, typically described as a beam of given width, expressed in degrees in the horizontal and vertical plane. (See Azimuth and Elevation Beamwidth below)

### Type

**Panel:** A flat antenna that is mounted to a wall or other vertical surface and radiates RF energy (radio waves) directionally away from the wall.

They usually have gain greater than 5 dBi and are not suitable for omni-directional situations. Ideally suited for long hallways.

**Patch:** A flat antenna that is mounted on the ceiling but whose pattern is omni-directional. Most of the energy goes out horizontally to the sides of the antenna and equal in all directions.

**Dipole:** A tubular antenna that can be either a pipe shape, a straight flexible rod or a paddle. This antenna has an omni-directional pattern when placed in a vertical position. It usually has 2 dBi of gain.

**Dipole Array:** Essentially a dipole, a dipole array is two or more dipoles that are placed one on top of the other, requiring a longer tube to hold them. The advantage of a dipole array is that it has higher gain.

**Parabolic Grid: (PGA)** A very directional, dish-like antenna. Its parabolic reflector focuses the RF energy like a flashlight. Most of the time the radiating element is a dipole, but when combined with the dish, it becomes very directional with gain up to 24 dBi. Usually used in long point-to-point systems.

**Yagi:** An antenna that has an internal structure resembling that of typical antennas used for TV reception (a series of rods perpendicular to a main rod, making a triangular shape). This is a directional antenna with less gain than the PGA, typically around 13 dBi. It may be used in either point-to-point situations, or to cover a very long, narrow area in point-to-multi-point situations.

### Additional terms

**Frequency:** the frequency band within which the antenna performs at the stated specifications.

**Gain (dBi):** The relative amplification of the antenna with respect to an equivalent isotropic antenna, expressed on the decibel logarithmic scale.

**Cable loss (dB):** The signal strength loss introduced by the cable connected to the antenna expressed on the decibel logarithmic scale.

**Net gain (dBi):** The resulting amplification of the antenna paired with its cable.

**Polarization:** the orientation of the electrical field which the antenna is optimized to receive. If the transmitting and receiving antennas are both linear polarized, then turning one 90° so that they are cross polarized will reduce the range significantly.

**VSWR:** Voltage Standing Wave Ratio. The ratio of maximum voltage to minimum voltage along the line. Expresses the degree of match between the transmission line and the terminating element (antenna). When VSWR is 1:1 the match is perfect, a VSWR of 1.5:1 corresponds to 96% power efficiency.

**Azimuth 3dB Beamwidth:** width of the antenna beam on the horizontal plane expressed in degrees.

**Elevation 3dB Beamwidth:** height of the antenna beam on the vertical plane expressed in degrees.

## Antennas and related accessories for Motorola's Enterprise WLANs

Motorola offers a complete selection of antennas and accessories to ensure optimal coverage and performance for 802.11a/b/g wireless LANs. Regardless of the size or layout of your environment, from a small office or storefront to campus-wide, multiple-site, indoor and outdoor deployments, Motorola offers the antennas, cables and accessories designed to fit your needs.

By combining this portfolio with a broad line of wireless switches, access ports, access points, client connectivity cards, ruggedized mobile voice/data devices and network management software, as well as wireless mobility planning and deployment services, Motorola offers comprehensive end-to-end wireless enterprise LAN solutions, giving you secure, reliable access to your critical business data and applications at the point of activity. For more information on Motorola's wireless products, visit [www.symbol.com/wireless](http://www.symbol.com/wireless)

### Choosing the right antenna and accessories for your Motorola enterprise WLAN

It is important to consider a number of factors when choosing an antenna and accessories for your Motorola enterprise WLAN. In order to choose the right components, you'll need to know:

- Where you will be installing the antenna, and what type of coverage you will require
- In which band (i.e. 802.11b/g or 802.11a) your network operates
- Which Motorola AP you plan to use
- Whether you will be deploying the network indoors or outdoors
- The distance between AP and antenna, to determine extender cable length, if any

With this information, review the tables below and determine which antennas might suit your needs. Using the part numbers provided in the tables, go to the compatibility chart on page 5 to determine which of the possible antennas will work with your hardware in your environment. If you'd prefer, you may go to the compatibility chart first, and then look up the antennas listed in the table below to find the one that best meets your needs.

# Product compatibility chart

To find the right antenna and accessories for your deployment:

1. Find your AP at the top of the chart, and follow that column down to find the antennas, cables and lightning arrestors that are compatible with that AP. Write those part numbers down.

2. Follow the row of the chosen antenna across the table to the columns for the lightning arrestors and cables you wrote down to confirm that they are also compatible with the antenna you've chosen and to determine if an adaptor is required to connect two selected parts.

		AP Radios						Cables					LAs			
		AP300 A	AP300 B/G	AP-5131 A	AP-5131 B/G	AP-5181 A	AP-5181 B/G	ML-1499-100JK-01R	ML-1499-10JK-01R	ML-1499-25JK-01R	ML-1499-50JK-01R	ML-1499-72PJ-01R	ML-1499-LAK1-01R	ML-1499-LAK2-01R	ML-2452-LAK1-01R	
Antennas	2.4 GHz	ML-2499-11PNA2-01R	X	•	X	3	X	X	1	1	1	1	•	2	2	2
		ML-2499-5PNL-72-N	X	8	X	7	X	X	A	A	A	A	X	•	•	•
		ML-2499-7PNA2-01R	X	•	X	3	X	X	1	1	1	1	•	2	2	2
		ML-2499-APA2-01	X	•	X	•	X	X	X	X	X	X	X	X	X	X
		ML-2499-BPNA3-01R	X	9	X	6	X	X	•	•	•	•	X	X	•	X
		ML-2499-BYGA2-01R	X	9	X	6	X	X	•	•	•	•	X	X	•	X
		ML-2499-FHPA5-01R	X	X	X	X	X	•	A	A	A	A	X	◆	◆	◆
		ML-2499-FHPA9-01R	X	X	X	X	X	•	A	A	A	A	X	◆	◆	◆
		ML-2499-HPA3-01R	X	•	X	•	X	X	1	1	1	1	•	2	2	2
		ML-2499-PNAHD-01R	X	•	X	3	X	X	1	1	1	1	•	2	2	2
		ML-2499-SD3-01R	X	•	•	3	X	X	1	1	1	1	•	2	2	2
Antennas	5 GHz	ML-5299-APA1-01R	•	X	•	X	X	X	X	X	X	X	X	X	X	X
		ML-5299-FHPA10-01R	X	X	X	X	•	X	A	A	A	A	X	◆	◆	◆
		ML-5299-FHPA6-01R	X	X	X	X	•	X	A	A	A	A	X	◆	◆	◆
		ML-5299-HPA1-01R	•	X	•	X	X	X	4	4	4	4	X	5	5	5
		ML-5299-PTA1-01R	•	X	•	X	X	X	4	4	4	4	X	5	5	5
		ML-5299-WPNA1-01R	•	X	•	X	X	X	4	4	4	4	X	5	5	5
Antennas	Dual	ML-2452-APA2-01	•	X	•	•	X	X	X	X	X	X	X	X	X	X
		ML-2452-PNA5-01R	X	X	X	X	•	•	A	A	A	A	X	◆	◆	◆
		ML-2452-PNA7-01R	X	X	X	X	•	•	A	A	A	A	X	◆	◆	◆
LAs	ML-1499-LAK1-01R	X	•	X	X	◆	◆	•	•	•	•	•				
	ML-1499-LAK2-01R	X	X	X	X	◆	◆	•	•	•	•	X				
	ML-2452-LAK1-01R	•	X	•	•	◆	◆	•	•	•	•	X				
Cables	ML-1499-100JK-01R	7	X	7	7	•	•									
	ML-1499-10JK-01R	7	X	7	7	•	•									
	ML-1499-25JK-01R	7	X	7	7	•	•									
	ML-1499-50JK-01R	7	X	7	7	•	•									
	ML-1499-72PJ-01R	X	•	X	X	X	X									

## Legend

- 1 - ML-1499-RBNCA1-01R
- 2 - ML-1499-RBNCA2-01R
- 3 - 25-72178-01
- 4 - 25-90262-01R
- 5 - 25-90263-01R
- 6 - 25-85391-01R
- 7 - 25-85392-01R
- 8 - Must use ML-1499-LAK1-01R
- 9 - 25-97261-01R
- A - 25-99175-01R

- - Compatible
- X - Not Compatible
- ◆ - Not Required

# Antenna part number and description tables

## 2.4 GHz (802.11b/g/n) Antennas

### Part Number: ML-2499-5PNL-72-N

#### High Performance 135 Degree Panel Antenna - 5.5 dBi; N Male Connector

##### Specifications:

Type: Panel  
 Frequency: 2400-2500 MHz  
 Gain (dBi): 7.5  
 Net Gain (dBi): 5.5  
 Cable Loss (dB): 2  
 Polarization: Linear, Vertical  
 VSWR: 1.7:1  
 Azimuth 3dB Beamwidth: 135°  
 Elevation 3dB Beamwidth: 56°  
 Cable Length (in.): 72  
 Cable Attenuation (dB/100 ft.): 33.5  
 Cable Type: RG-58 Ultralink  
 Connector Type: Type N – Male  
 Power: 25 W  
 Weight: .5 lb

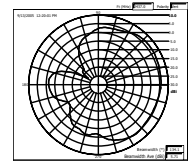
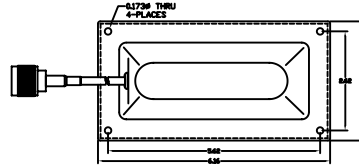

Azimuth Pattern

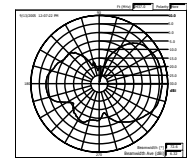
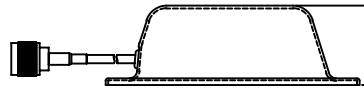

Elevation Pattern

### Part Number: ML-2499-7PNA2-01R

#### 65 Degree H-Plane Diversity Directional Panel - 7 dBi, RP-BNC Male

##### Specifications:

Type: Panel  
 Frequency: 2400-2500 MHz  
 Gain (dBi): 7.6  
 Net Gain (dBi): 6.3  
 Cable Loss (dB): 1.3  
 Polarization: Linear, Vertical  
 VSWR: 1.7:1 Typical  
 Azimuth 3dB Beamwidth: 60°  
 Elevation 3dB Beamwidth: 60°  
 Cable Length (in.): 48  
 Cable Attenuation (dB/100 ft.): 33.5  
 Cable Type: RG-58 Ultralink  
 Connector Type: RP-BNC Male  
 Power: 10 W  
 Weight: 9.6 oz

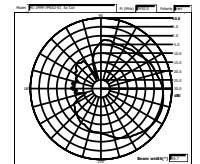
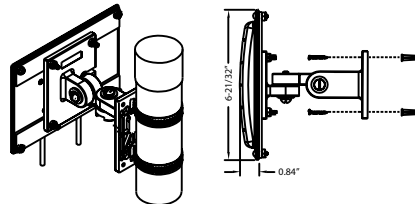

Azimuth Pattern

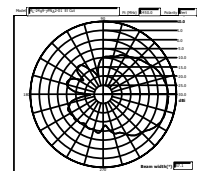
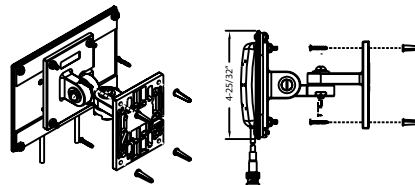

Elevation Pattern

**Part Number: ML-2499-11PNA2-01R**

**High-Gain 97 Degree H-Plane Directional Panel - 11 dBi, RP-BNC Male**

**Specifications:**

Type: Panel  
Frequency: 2400-2500 MHz  
Gain (dBi): 11.2  
Net Gain (dBi): 8.5  
Cable Loss (dB): 2.7  
Polarization: Linear, Vertical  
VSWR: 1.7:1 Typical  
Azimuth 3dB Beamwidth: 97°  
Elevation 3dB Beamwidth: 14°  
Cable Length (in.): 96  
Cable Attenuation (dB/100 ft.): 33.5  
Cable Type: RG-58 Ultralink  
Connector Type: RP-BNC-Male  
Power: 50 W  
Weight: 1.5 lb

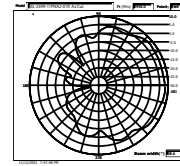
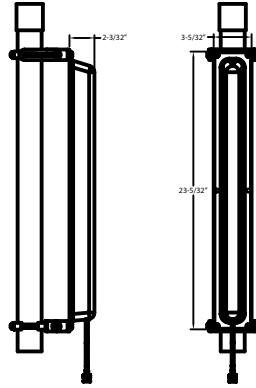

Azimuth Pattern

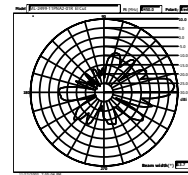

Elevation Pattern

**Part Number: ML-2499-APA2-01R**

**High Performance Omni-Directional 'Fixed Point' Dipole - 3.5 dBi, RP-BNC Male**

**Specifications:**

Type: Dipole  
Frequency: 2400-2500 MHz  
Gain (dBi): 2  
Net Gain (dBi): 2  
Cable Loss (dB): 0  
Polarization: Linear, Vertical  
VSWR: 1.7:1 Typical  
Azimuth 3dB Beamwidth: 360°  
Elevation 3dB Beamwidth: 60°  
Cable Length (in.): 0  
Cable Attenuation (dB/100 ft.): N/A  
Cable Type: N/A  
Connector Type: RP-BNC Female  
Power: 2 W  
Weight: 1.2 oz

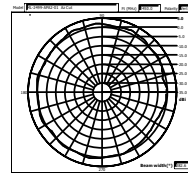
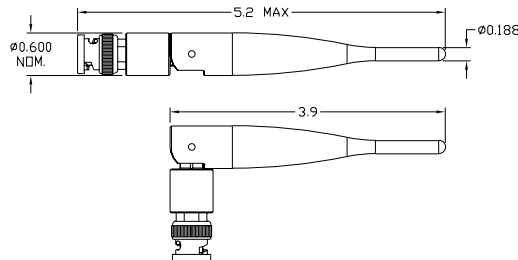

Azimuth Pattern

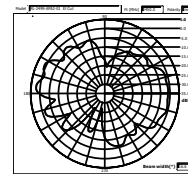

Elevation Pattern

**Part Number: ML-2499-BPDA1-01R**

**Heavy-Duty 10 Degree Directional High-Gain Parabolic Dish - 24 dBi, N Female**

**Specifications:**

Type: Parabolic Dish  
Frequency: 2400-2500 MHz  
Gain (dBi): 23.5  
Net Gain (dBi): 23.5  
Cable Loss (dB): 0  
Polarization: Linear, Vertical  
VSWR: 1.7:1 Typical  
Azimuth 3dB Beamwidth: 10°  
Elevation 3dB Beamwidth: 11°  
Cable Length (in.): 0  
Cable Attenuation (dB/100 ft.): N/A  
Cable Type: N/A  
Connector Type: Type N – Female  
Power: 50 W  
Weight: 13 lb

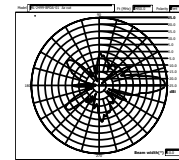
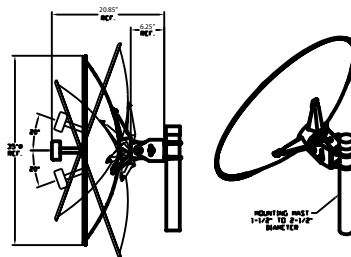

Azimuth Pattern

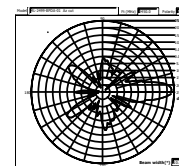

Elevation Pattern

**Part Number: ML-2499-BPNA3-01R**

**Heavy-Duty 35 Degree High-Gain Directional Panel - 14.5 dBi, N Female**

**Specifications:**

Type: Panel  
Frequency: 2400-2500 MHz  
Gain (dBi): 13.9  
Net Gain (dBi): 13.6  
Cable Loss (dB): .3  
Polarization: Linear, Vertical  
VSWR: 1.5:1  
Azimuth 3dB Beamwidth: 31°  
Elevation 3dB Beamwidth: 28°  
Cable Length (in.): 12  
Cable Attenuation (dB/100 ft.): 33.5  
Cable Type: RG-58 Ultralink  
Connector Type: N – Female  
Power: 50 W  
Weight: 1.5 lb

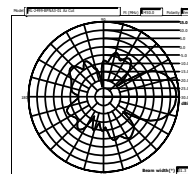
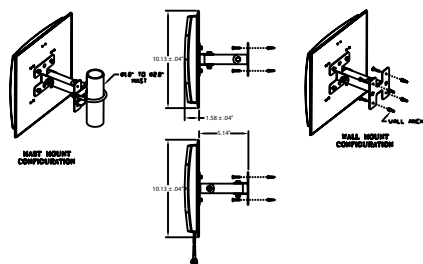

Azimuth Pattern

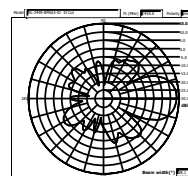

Elevation Pattern



**Part Number: ML-2499-BYGA2-01R**

**Heavy-Duty 35 Degree High-Gain Directional Yagi - 15 dBi, N Female**

**Specifications:**

Type: Yagi  
Frequency: 2400-2500 MHz  
Gain (dBi): 14.1  
Net Gain (dBi): 13.9  
Cable Loss (dB): .3  
Polarization: Linear, Vertical  
VSWR: 1.5:1 Typical  
Azimuth 3dB Beamwidth: 28°  
Elevation 3dB Beamwidth: 27°  
Cable Length (in.): 12  
Cable Attenuation (dB/100 ft.): 33.5  
Cable Type: RG-58 Ultralink  
Connector Type: Type N – Female  
Power: 50 W  
Weight: 1.25 lb

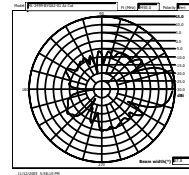
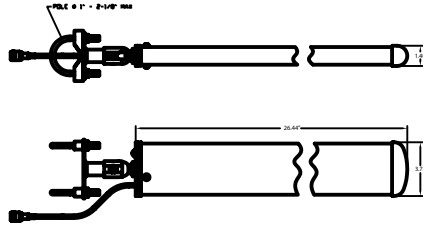

Azimuth Pattern

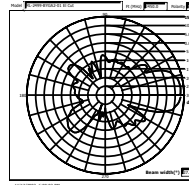

Elevation Pattern

**Part Number: ML-2499-HPA3-01R**

**High Performance Omni-Directional "Pipe" Antenna - 5 dBi, RP-BNC Male**

**Specifications:**

Type: Dipole Array  
Frequency: 2400-2500 MHz  
Gain (dBi): 4.6  
Net Gain (dBi): 3.3  
Cable Loss (dB): 1.3  
Polarization: Linear, Vertical  
VSWR: 1.7:1  
Azimuth 3dB Beamwidth: 360°  
Elevation 3dB Beamwidth: 31°  
Cable Length (in.): 48  
Cable Attenuation (dB/100 ft.): 33.5  
Cable Type: RG-58 Ultralink  
Connector Type: RP-BNC Male  
Power: 50 W  
Weight: .03 lb

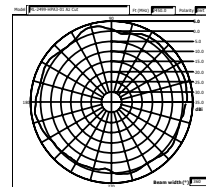
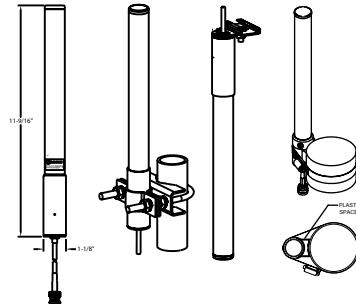

Azimuth Pattern

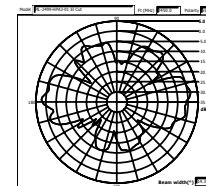

Elevation Pattern

---

**Part Number: ML-2499-PNAHD-01R****Heavy-Duty 65 Degree H-Plane Directional Panel - 6.3 dBi, RP-BNC Male**

---

**Specifications:**

Type: Panel  
Frequency: 2400-2500 MHz  
Gain (dBi): 7.6  
Net Gain (dBi): 6.3  
Cable Loss (dB): 1.3  
Polarization: Linear, Vertical  
VSWR: 1.7:1  
Azimuth 3dB Beamwidth: 55°  
Elevation 3dB Beamwidth: 56°  
Cable Length (in.): 48  
Cable Attenuation (dB/100 ft.): 33.5  
Cable Type: RG-58 Ultralink  
Connector Type: RP-BNC Male  
Power: 50 W  
Weight: .5 lb

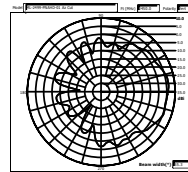
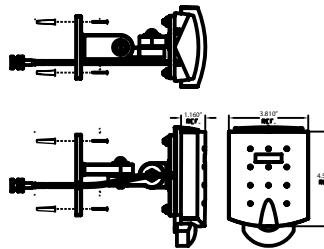

Azimuth Pattern

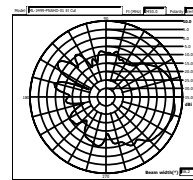

Elevation Pattern

---

**Part Number: ML-2499-SD3-01R****Low Profile Ceiling/Surface Mount Omni-Directional - 3.5 dBi, RP-BNC Male**

---

**Specifications:**

Type: Panel  
Frequency: 2400-2500 MHz  
Gain (dBi): 4.8  
Net Gain (dBi): 3.5  
Cable Loss (dB): 1.3  
Polarization: Linear, Vertical  
VSWR: 1.7:1  
Azimuth 3dB Beamwidth: 360°  
Elevation 3dB Beamwidth: 52°  
Cable Length (in.): 48  
Cable Attenuation (dB/100 ft.): 33.5  
Cable Type: RG-58 Ultralink  
Connector Type: RP-BNC Male  
Power: 10 W  
Weight: 3.2 oz

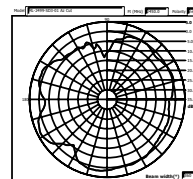
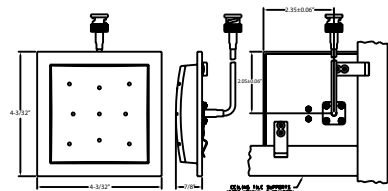

Azimuth Pattern

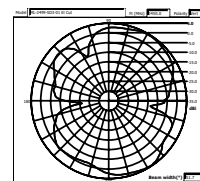

Elevation Pattern

---

**Part Number: ML-2499-FHPA5-01R**

**Omni-Directional "Pipe" Antenna - 7.7 dBi, N Male Connector**

---

**Specifications:**

Type: Dipole Array  
Frequency: 2400-2500 MHz  
Gain (dBi): 7.7  
Net Gain (dBi): 7.7  
Cable Loss (dB): 0.0  
Polarization: Linear, Vertical  
VSWR: 2:1  
Azimuth 3dB Beamwidth: 360°  
Elevation 3dB Beamwidth: 25°  
Cable Length (in.): N/A  
Cable Attenuation (dB/100 ft.): N/A  
Cable Type: N/A  
Connector Type: Type N – Male  
Power: 10 W  
Weight: .7 (.3)

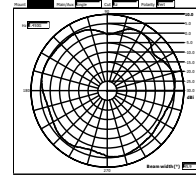

Azimuth Pattern  
2450 MHz

---

**Part Number: ML-2499-FHPA9-01R**

**Omni-Directional "Pipe" Antenna - 9 dBi, N Male Connector**

---

**Specifications:**

Type: Dipole Array  
Frequency: 2400-2500 MHz  
Gain (dBi): 9.0  
Net Gain (dBi): 9.0  
Cable Loss (dB): 0  
Polarization: Linear, Vertical  
VSWR: 2:1  
Azimuth 3dB Beamwidth: 360°  
Elevation 3dB Beamwidth: 14°  
Cable Length (in.): N/A  
Cable Attenuation (dB/100 ft.): N/A  
Cable Type: N/A  
Connector Type: Type N – Male  
Power: 10 W  
Weight: 1.1 (.5)

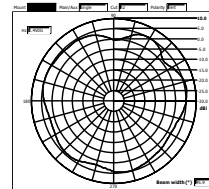

Azimuth Pattern  
2450 MHz

## 5.2 GHz (802.11a) Antennas

### Part Number: ML-5299-APA1-01R

#### High Performance Fixed Point Dipole - 2 dBi, RP-SMA Female Connector

##### Specifications:

Type: Dipole  
 Frequency: 4900-5875 MHz  
 Gain (dBi): 2.0/2.0  
 Net Gain (dBi): 2.0/2.0  
 Cable Loss (dB): N/A  
 Polarization: Linear, Vertical  
 VSWR: 1.5:1  
 Azimuth 3dB Beamwidth: 360°  
 Elevation 3dB Beamwidth: 75°  
 Cable Length (in.): N/A  
 Cable Attenuation (dB/100 ft.): N/A  
 Cable Type: N/A  
 Connector Type: RP-SMA Male  
 Power: 1 W  
 Weight: 1 oz

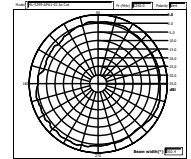
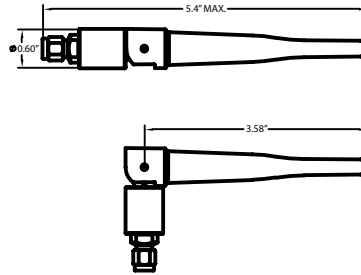

Azimuth Pattern

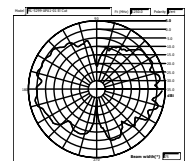

Elevation Pattern

### Part Number: ML-5299-HPA1-01R

#### High Performance Omni-Directional Antenna - 5 dBi, RP-SMA Female Connector

##### Specifications:

Type: Dipole Array  
 Frequency: 4900-5875 MHz  
 Gain (dBi): 5.9  
 Net Gain (dBi): 5  
 Cable Loss (dB): .84  
 Polarization: Linear, Vertical  
 VSWR: 2:1  
 Azimuth 3dB Beamwidth: 360°  
 Elevation 3dB Beamwidth: 17°  
 Cable Length (in.): 36  
 Cable Attenuation (dB/100 ft.): 28  
 Cable Type: LMR195  
 Connector Type: RP-SMA Male  
 Power: 5 W  
 Weight: 0.3 lb

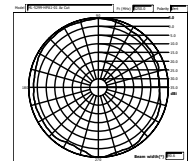
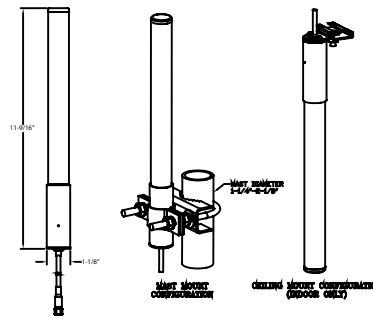

Azimuth Pattern

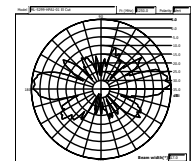

Elevation Pattern

---

**Part Number: ML-5299-PTA1-01R****Low Profile Ceiling-Tile Mount Panel - 2 dBi, RP-SMA Female Connector**

---

**Specifications:**

Type: Patch  
Frequency: 4900-5875 MHz  
Gain (dBi): 6.5/2.0  
Net Gain (dBi): 4.5/0  
Cable Loss (dB): 2  
Polarization: Linear, Vertical  
VSWR: 1.5:1  
Azimuth 3dB Beamwidth: 360°  
Elevation 3dB Beamwidth: 45°  
Cable Length (in.): 36  
Cable Attenuation (dB/100 ft.): 2.15  
Cable Type: RG-58  
Connector Type: RP-SMA Male  
Power: 2 W  
Weight: 2.4 lb

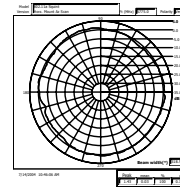
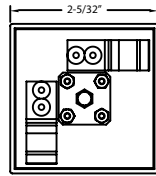
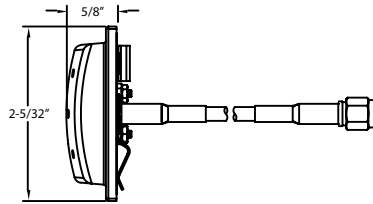

Azimuth Pattern

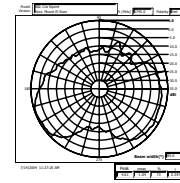

Elevation Pattern

---

**Part Number: ML-5299-WPNA1-01R****Wall Mount Panel Antenna w/Articulating Mount - 13 dBi, RP-SMA Female**

---

**Specifications:**

Type: Panel  
Frequency: 4900-5875 MHz  
Gain (dBi): 14.2  
Net Gain (dBi): 13  
Cable Loss (dB): 1.2  
Polarization: Linear, Vertical  
VSWR: 2:1  
Azimuth 3dB Beamwidth: 31°  
Elevation 3dB Beamwidth: 27°  
Cable Length (in.): 36  
Cable Attenuation (dB/100 ft.): 40  
Cable Type: RG-303  
Connector Type: RP-SMA Male  
Power: 10 W  
Weight: 0.7 lb

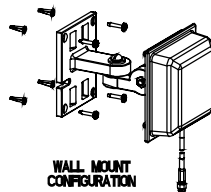

WALL MOUNT CONFIGURATION

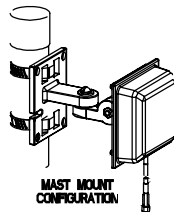

MAST MOUNT CONFIGURATION

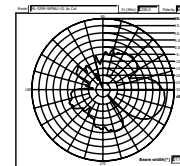
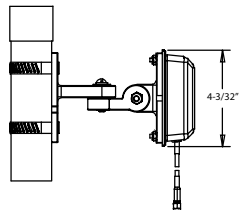
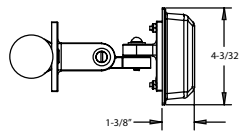

Azimuth Pattern

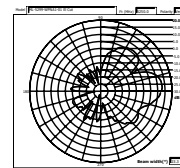

Elevation Pattern

---

**Part Number: ML-5299-FHPA10-01R**

**Omni-Directional "Pipe" Antenna, 10 dBi, N-Male Connector**

---

**Specifications:**

Type: Dipole Array  
Frequency: 4900-5850 MHz  
Gain (dBi): 10.0  
Net Gain (dBi): 10.0  
Cable Loss (dB): 0.0  
Polarization: Linear, Vertical  
VSWR: 2:1  
Azimuth 3dB Beamwidth: 360°  
Elevation 3dB Beamwidth: 13°  
Cable Length (in.): N/A  
Cable Attenuation (dB/100 ft.): N/A  
Cable Type: N/A  
Connector Type: Type N – Male  
Power: 5 W  
Weight: .37 (.17)

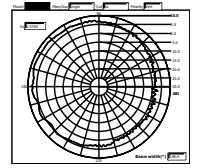

Azimuth Pattern  
5570 MHz

---

**Part Number: ML-5299-FHPA6-01R**

**Omni-Directional "Pipe" Antenna, 8 dBi, N-Male Connector**

---

**Specifications:**

Type: Dipole Array  
Frequency: 4900-5850 MHz  
Gain (dBi): 8.0  
Net Gain (dBi): 8.0  
Cable Loss (dB): 0.0  
Polarization: Linear, Vertical  
VSWR: 2:1  
Azimuth 3dB Beamwidth: 360°  
Elevation 3dB Beamwidth: 16°  
Cable Length (in.): N/A  
Cable Attenuation (dB/100 ft.): N/A  
Cable Type: N/A  
Connector Type: Type N – Male  
Power: 5 W  
Weight: .37 (.17)

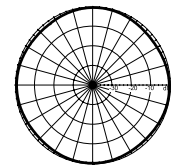

Azimuth Pattern  
5500 MHz

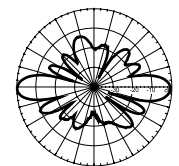

Elevation Pattern  
5500 MHz

## 2.4GHz - 5.2GHz Dual Band Antennas

### Part Number: ML-2452-APA2-01

#### High Performance Dual Band Fixed Point Dipole - 3 dBi/4 dBi, RP-SMA Female

##### Specifications:

Type: Dipole  
 Frequency: 2400-2500/5150-5850 MHz  
 Gain (dBi): 3,4  
 Net Gain (dBi): 3,4  
 Cable Loss (dB): N/A  
 Polarization: Linear, Vertical  
 VSWR: 1.92:1  
 Azimuth 3dB Beamwidth: 360°  
 Elevation 3dB Beamwidth: 35°  
 Cable Length (in.): N/A  
 Cable Attenuation (dB/100 ft.): N/A  
 Cable Type: N/A  
 Connector Type: RP-SMA Male  
 Power: 10 W  
 Weight: 0.7 oz

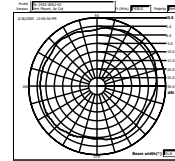
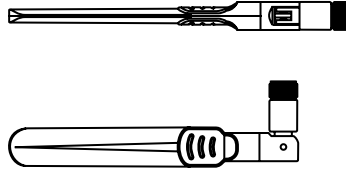

Azimuth Pattern

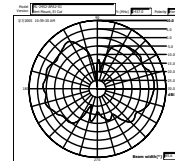

Elevation Pattern

### Part Number: ML-2452-PNA5-01R

#### Dual Band Panel, 5 dBi, Connector Type N-Male

##### Specifications:

Type: Panel  
 Frequency: 2400-2500/4900-5900 MHz  
 Gain (dBi): 4.5 (2400-2500); 5.0 (4900-5250);  
 7.5 (5250-5900)  
 Polarization: Linear, Vertical  
 VSWR: 2:1  
 Azimuth 3dB Beamwidth: 120°  
 Elevation 3dB Beamwidth: 65°  
 Cable Length (in.): 30.5  
 Cable Attenuation (dB/100 ft.): 1.01/1.96  
 Cable Type: RG-58 Ultralink  
 Connector Type: Type N – Male  
 Power: 5 W  
 Weight: .2 (.09)

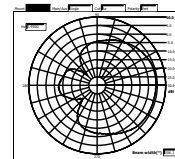

Azimuth Pattern  
2450 MHz

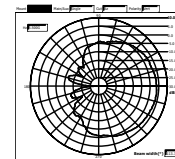

Elevation Pattern  
2450 MHz

---

**Part Number: ML-2452-PNA7-01R**  
**Dual Band Panel, 7 dBi, Connector Type N-Male**

---

**Specifications:**

Type: Panel  
Frequency: 2400-2500/4900-5900 MHz  
Gain (dBi): 7.8 (2400-2500); 7.0 (4900-5250);  
10.7 (5250-5900)  
Cable Loss (dB): 0.3/0.7  
Polarization: Linear, Vertical  
VSWR: 2:1  
Azimuth 3dB Beamwidth: 68°/ 52°  
Elevation 3dB Beamwidth: 66°/ 60°  
Cable Length (in.): 30.5  
Cable Attenuation (dB/100 ft.): 1.01/1.96  
Cable Type: RG-58 Ultralink  
Connector Type: Type N – Male  
Power: 10 W  
Weight: .5 (.23)

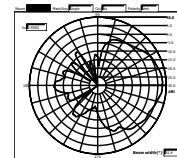

Azimuth Pattern  
2450 MHz

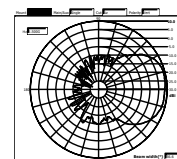

Elevation Pattern  
5500 MHz

---

**Cables**

---

**Part Number: ML-1499-100JK-01R**  
**100 ft. Low-Loss Coaxial Cable Jumper: N Male to N Male with 2 Connector Seal Kits**

---

**Specifications:**

Type: Ultralink TL 93605  
RF Connectors: N (m) to N (m)  
Cable Attenuation (dB): 10.6 @ 2.4 GHz; 15.5 @ 5.8 GHz  
Frequency: 2400-2500 MHz

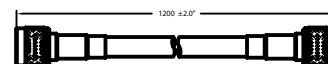

---

**Part Number: ML-1499-10JK-01R**  
**10 ft. Low-Loss Coaxial Cable Jumper: N Male to N Male**

---

**Specifications:**

Type: Ultralink TL 93605  
RF Connectors: N (m) to N (m)  
Cable Attenuation (dB): 2.0 @ 2.4 GHz; 2.9 @ 5.8 GHz  
Frequency: 2400-2500 MHz

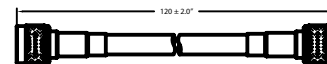

---

**Part Number: ML-1499-25JK-01R**  
**25 ft. Low-Loss Coaxial Cable Jumper: N Male to N Male with 2 Connector Seal Kits**

---

**Specifications:**

Type: Ultralink TL 93605  
RF Connectors: N (m) to N (m)  
Cable Attenuation (dB): 2.5 @ 2.4 GHz; 4.0 @ 5.8 GHz  
Frequency: 2400-2500 MHz

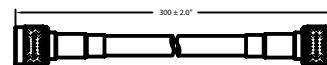



---

**Part Number: ML-1499-50JK-01R****50 ft. Low-Loss Coaxial Cable Jumper: N Male to N Male with 2 Connector Seal Kits**

---

**Specifications:**

Type: Ultralink TL 93605

RF Connectors: N (m) to N (m)

Cable Attenuation (dB): 4.5 @ 2.4 GHz; 7.0 @ 5.8 GHz

Frequency: 2400-2500 MHz

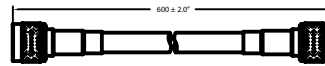

---

**Part Number: ML-1499-72PJ-01R****6 ft. RBN Female to RBN Male Plenum Coaxial Jumper**

---

**Specifications:**

Type: CMP Plenum, RG-58

RF Connectors: Rev. BNC (f) to Rev. BNC (m)

Cable Attenuation: .9 dB

Frequency: 2400-2500 MHz

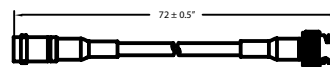

---

**Adapters**

---

**Part Number: ML-1499-RBNCA1-01R****1 ft. N Female to RBN Female Cable Adapter with Connector Seal Kit**

---

**Specifications:**

Type: Black, Ultralink, RG-58

RF Connectors: N (f) to Rev. BNC (f)

Frequency: 2400-2500 MHz

Attenuation: .2 dB

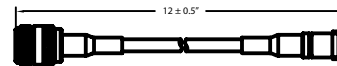

---

**Part Number: ML-1499-RBNCA2-01R****1 ft. N Male to RBN Female Cable Adapter with Connector Seal Kit**

---

**Specifications:**

Type: RG-58

Frequency: 2400-2500 MHz

Cable Loss (dB): .85

Cable Length (in.): 12

Connector 1: N – Male

Connector 2: RP-BNC-F

Power: 2 W

Color: Black

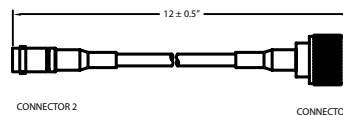

---

**Part Number: 25-85391-01R****3.5 in. Jumper Cable, RP-SMA (Female) to Type N (Male) Adaptor**

---

**Specifications:**

Type: Clear Jacket, RG-316

Connector 1: RP-SMA, Female

Connector 2: Type N, Male

Insertion Loss - 2.4 GHz: 0.2 dB MIN

Insertion Loss - 5.2 GHz: 0.3 dB MIN

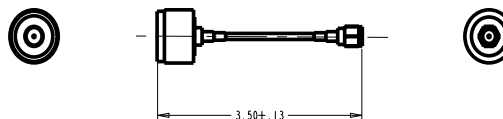

---

**Part Number: 25-85392-01R****3.5 in. Jumper Cable, RP-SMA (Female) To Type N (Female) Adapter**

---

**Specifications:**

Cable: RG-316  
Connector 1: RP-SMA, Female  
Connector 2: Type N, Female  
Insertion Loss - 2.4 GHz: 0.3 dB MIN  
Insertion Loss - 5.2 GHz: 0.4 dB MIN

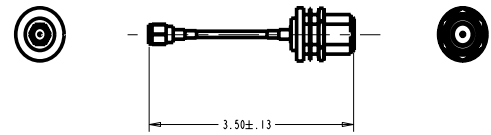

---

**Part Number: 25-72178-01****Jumper, RP-SMA(M) to RP-BNC(F)**

---

**Specifications:**

Cable: RG-316  
Connector 1: RP-SMA, Male  
Connector 2: RP-BNC, Female  
Insertion Loss - 2.4 GHz: .2 dB  
Insertion Loss - 5.2 GHz: .3 dB

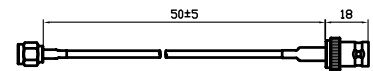

---

**Part Number: 25-90262-01R****RP-SMA (Female) to Type N (Female) Adapter**

---

**Specifications:**

Cable: RG-316  
Connector 1: RP-SMA, Female  
Connector 2: Type N, Female  
Insertion Loss - 2.4 GHz: .3 dB  
Insertion Loss - 5.2 GHz: .4 dB

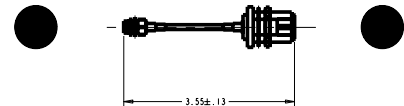

---

**Part Number: 25-90263-01R****Type N (Male) to RP-SMA (Female) Bulkhead Adapter**

---

**Specifications:**

Cable: RG-316  
Connector 1: Type N, Male  
Connector 2: RP-SMA, Female, bulkhead  
Insertion Loss - 2.4 GHz: 0.2 dB MIN  
Insertion Loss - 5.2 GHz: 0.2 dB MIN

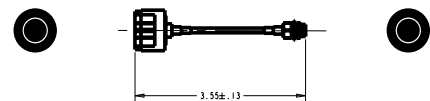

---

**Lightning Arrestors**

---

**Part Number: ML-1499-LAK1-01R****1 ft. N Male to RBN Male Lightning Arrestor with Connector Seal Kit**

---

**Specifications:**

Cable: Black, Ultralink, RG-58  
RF Connectors: N (m) to Rev. BNC (m)  
Arrestor RF Connectors: N (f) to N (f)  
Frequency: 2400-2500 MHz  
Insertion Loss: 0.25 dB

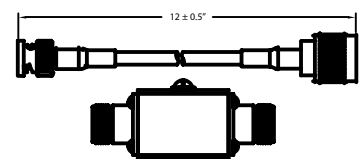

---

**Part Number: ML-1499-LAK2-01R****Lightning Arrestor Kit with N Male to N Male Barrel Adapter**

---

**Specifications:**

RF Connectors: N (m) to N (m)  
Arrestor RF Connectors: N (f) to N (f)  
Frequency: 2400-2500 MHz  
Maximum RF Power: 100 W  
Insertion Loss: 0.25 dB

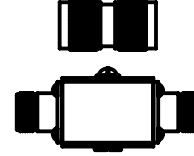

---

**Part Number: ML-2452-LAK1-01R****Lightning Arrestor (N Female to N Female) with N Male to RP-SMA Male Adapter**

---

**Specifications:**

Cable: Black, Ultralink, RG-58  
RF Connectors: N (m) to Rev. SMA (m)  
Frequency: 100-6000 MHz  
Maximum RF Power: 200 W  
VSWR (50 ohm): 1.4:1 dB Max  
Insertion Loss: 0.4 dB Max  
Insulation Resistance: 50 M-ohms  
Connectors: Type N (f) to N (f)  
Weight: 4.5 oz  
Operating Temperature: - 40° to 85°C

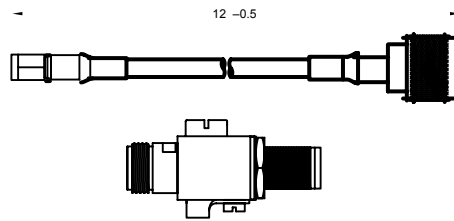

---

**Mounting Kits****Part Number: ML-1499-APAMK-01R****Magnetic Base for ML-2452-APA2-01 with 6 Ft. Cable RP-SMA (Male)**

---

**Specifications:**

Cable: RG-178  
Connector 1: RP-SMA, Male  
Connector 2: RP-SMA, Female  
Attenuation (dB): 2.6 @ 2.4 GHz; 4.6 @ 5.5 GHz

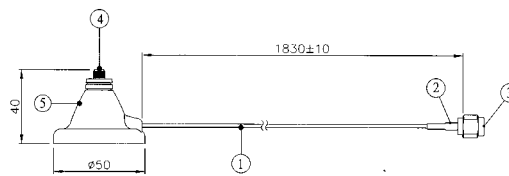

---

**Part Number: ML-1499-SD3MK-01R****Articulating I-Beam Mount Kit for ML-2499-SD3-01 Omni Antenna**

---

**Specifications:**

Use to mount p/n ML-2499-SD3-01 to I-beam.

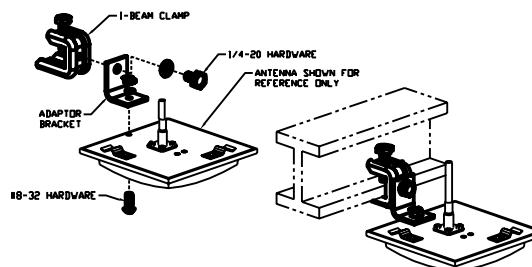

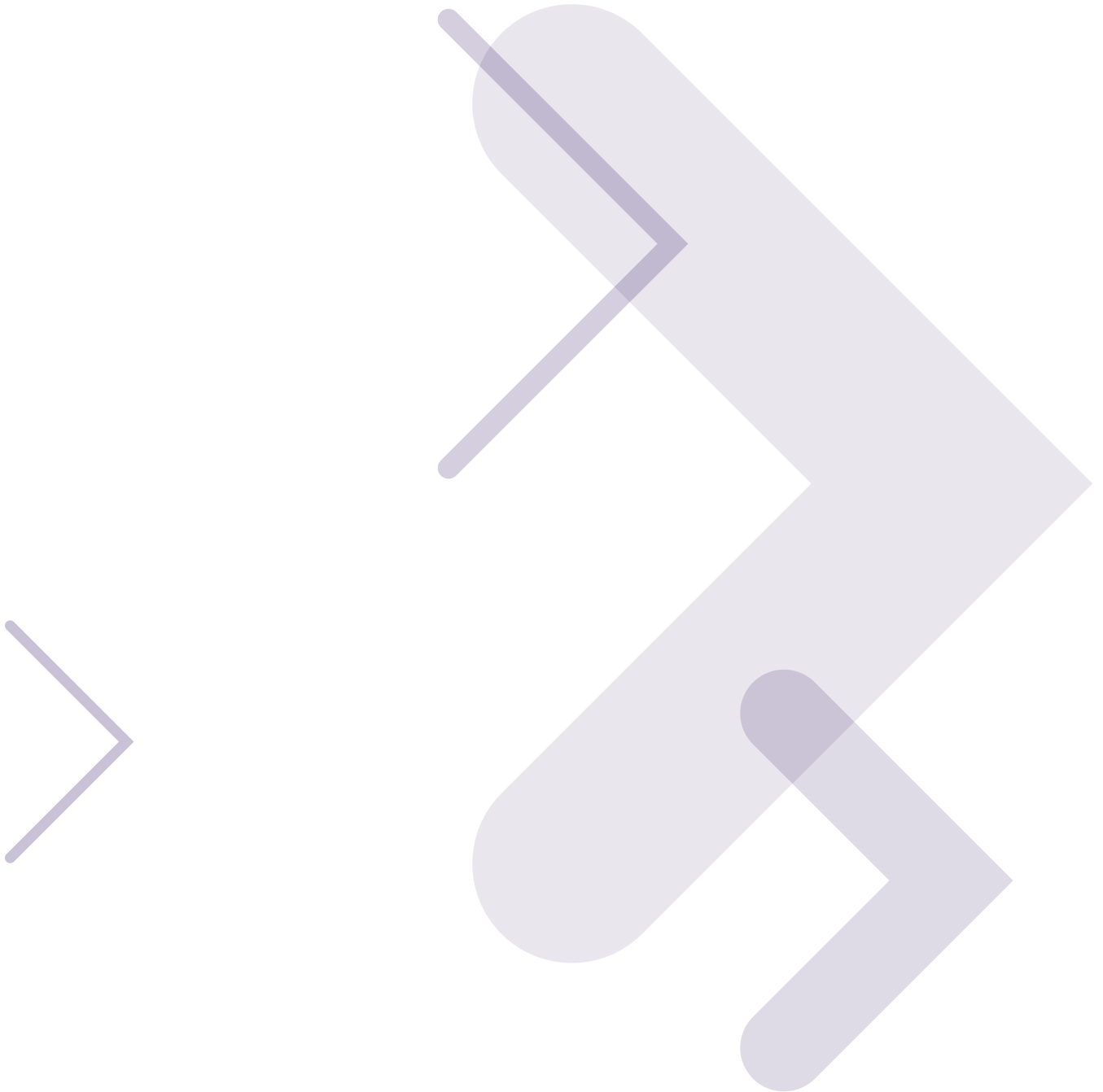

**MOTOROLA**

Part number BR-WIDANT. Printed in USA 06/07. MOTOROLA and the Stylized M Logo and SYMBOL and the SYMBOL Logo are registered in the US Patent & Trademark Office. All other product or service names are the property of their respective owners. ©2007 Motorola, Inc. All rights reserved. For system, product or services availability and specific information within your country, please contact your local Motorola office or Business Partner. Specifications are subject to change without notice.